

94 Series Actuators

The Shore Western 94 Series Linear Actuator is designed for extended service in demanding applications. Typical applications include

- Tests producing high side load forces on the actuator
- Low amplitude, high frequency vibration testing
- Test applications where static support is required for heavy specimens
- Tests requiring low harmonic distortion such as resonance frequency analysis

94 Series Actuators offer standard stroke lengths of 2, 4 and 6 inches (50, 100, 150 mm) and force ratings from 2.2 KIP (10 kN) to 35 KIP (160 kN). A double ended, one piece piston rod and hydrostatic bearings create an actuator able to withstand high side-load forces, eliminating wear on the rod or bearings.

Features

Displacement transducer

All actuators have a coaxially mounted LVDT in the piston rod.

Flow options

Integral servo valve manifold with oversize ports and provisions for interfacing to a variety of servo valves and service manifolds. The design provides for fluid conditioning and low/high pressure control and allows the actuator to accept a number of servo-valves with flow rates ranging from 1 to 90 gpm (4 to 340 L/min)

Hydraulic cushions

The piston and end caps are protected during full stroke or high velocity operations.

Hydrostatic bearings

Heavy duty hydrostatic bearing at both ends of the actuator allow it to react significant side loads without damage to the actuator rod. Shore Western utilizes non metallic coated bearing surfaces for all bearings to provide additional safety margins. Shore Western's proprietary seal design allows hydraulic fluid to return to the hydraulic power supply without the need for a scavenge pump. External drain back connections between low pressure and high pressure seals assure no external leakage in high velocity operation.

Large diameter piston rod

Large diameter, one piece piston rod of 100,000 psi yield material for infinite fatigue life, providing strength and maximum lateral stiffness. The chrome plated piston rod is micro ground and super-polished to minimize wear and friction in severe service. Large rod end attachment points to provide fatigue resistant specimen mounting.

Polymer piston rod protection

Hydrostatic bearings include a polymer liner that protects the piston rod from a catastrophic failure if side-load forces exceed the hydrostatic bearing capacity. The piston rod will contact the polymer liner if



a problem occurs saving the actuator, which can be serviced instead of replaced.

Heavy walled actuator body

A heavy wall, rigid actuator body provides for high side-load tolerance and helps to increase the resonant frequency of the actuator. The actuator bore is micro-honed for low friction and the actuator's modular construction allows flexibility in actuator working area and mounting configurations.

Options

Pedestal base

Utilizing a pedestal base allows rigid attachment of the actuator to a reaction mass for vertical vibration test applications.

Specimen mounting table

Adding a high frequency specimen mounting table to a pedestal base mounted 94 Series Actuator allows you to create a high-performance vibration test system.

Swivels

Either the Series 98 Rod End Swivels or Shore Western's Ball Swivels can help reduce side loads on the actuator rod.

Load Bias System

Pressurized nitrogen in a cavity inside the lower end cap of the actuator provides a static force to counteract the weight of heavy specimens or fixtures. A Load Bias System reduces the required actuator force and system flow requirements for improved performance as compared to a system with an unsupported payload.

Special manifolds

A variety of servo-valves, manifolds and close-coupled accumulator options can help customize an actuator for high-velocity applications.

Stroke lengths

Custom stroke lengths are available upon request.

MODEL NUMBER	RATING KIP	ROD DIA. INCHES	AREA IN ²	FORCE @ 3000 PSI LBF	OVERALL LENGTH 2" STROKE @ MIDSTROKE	OVERALL LENGTH 4" STROKE @ MIDSTROKE	OVERALL LENGTH 6" STROKE @ MIDSTROKE
942	2.2	2.75	0.77	2,310	18.0	23.0	28.0
942	3.3	2.75	1.17	3,510	18.0	23.0	28.0
942	5.5	2.75	2.02	6,060	18.0	23.0	28.0
942	7.7	2.75	2.57	7,710	18.0	23.0	28.0
942	11	2.75	2.75	8,250	18.0	23.0	28.0
943	22	3.75	7.42	22,260	19.7	24.7	29.7
943	35	3.75	11.78	35,340	19.7	24.7	29.7

MODEL NUMBER	RATING kN	ROD DIA. MM	AREA MM ²	FORCE @ 208 BAR kN	OVERALL LENGTH 50MM STROKE @ MIDSTROKE	OVERALL LENGTH 100MM STROKE @ MIDSTROKE	OVERALL LENGTH 150MM STROKE @ MIDSTROKE
942	10	70	497	10.28	457	584	711
942	15	70	755	15.61	457	584	711
942	24	70	1303	26.96	457	584	711
942	34	70	1658	34.30	457	584	711
942	49	70	1774	36.70	457	584	711
943	98	95	4787	99.02	500	627	754
943	156	95	7600	157.20	500	627	754

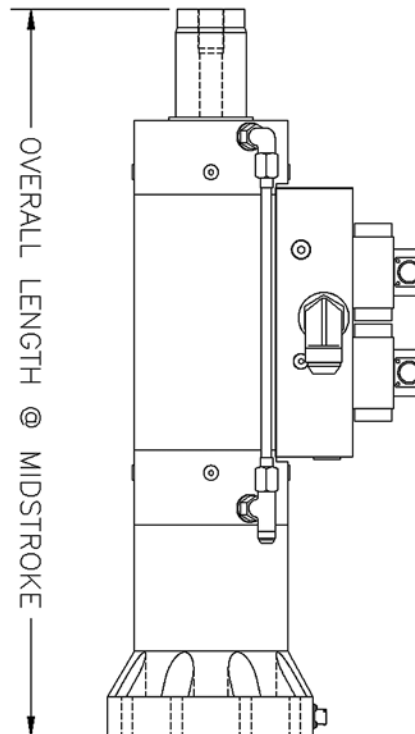

Represented by:



Shore Western Manufacturing, Inc.
 225 W. Duarte Rd., Monrovia, CA 91016
 Phone (626) 357-3251 / FAX (626) 303-1582
 email sales@shorewestern.com
 www.shorewestern.com